

Design Guidelines for **SHOPFRONT SECURITY**



Planning permission is required for the erection of a shutter to the outside of a shopfront.

This guidance addresses concerns about shopfront security and especially the needs of small retailers in the Borough, and is written in recognition of the fact that some retailers are suffering repeated attacks to their properties. The Council is sympathetic to the problem and here offers further guidance on what is and is not acceptable in terms of security shutters in the Borough. Retailers and their agents should also refer to the Council's Design Guidelines for Shopfronts and Shop Signs. The Council's Design Guidelines for Shopfronts and Shop Signs. The Council's policy as set out in the Unitary Development Plan (Policy ENV 28) is that "...shutters where acceptable in principle must be appropriate to the character of the shopfront and its setting: external security grilles will not normally be permitted..." In applying the policy the Council will refer to the following guidelines.

The Council will resist the installation of solid and perforated roller shutters on shopfronts throughout the Borough.

Solid roller shutters may appear an attractive solution to the retailer who has security concerns or who has had to continually replace glazing due to vandalism. However, they also have disadvantages. It is possible for a determined burglar to 'peel' them open and, once inside the premises, be hidden from view to carry out illegal and destructive activities at leisure.

The second problem is that once a row of shops has these shutters they can create a 'fortress environment'; this means that the street presents an unfriendly face and natural surveillance provided by passers by decreases because people simply avoid the area, seeing it as hostile. This may affect trade as customers seek out what they perceive to be safer areas to do their shopping. Furthermore, shutters can attract graffiti which makes the environment even worse. Due to the rubbing together of the laths on opening and closing, even powder coated paint will eventually wear off resulting in an even more down-at-heel and threatening environment.

Perforated shutters are sometimes seen as an alternative to completely solid shutters since, when back-lit from a shop window, they become virtually transparent. However, this effect is limited to a relatively small area in front of the shopfront itself. From an angle they appear to be solid. Also, because of their solid to void ratio they are attractive to the graffiti artist. For these reasons they are not considered appropriate for use in the Borough.

External 'brick bond' grilles

The Council will not normally permit the use of external brick-bond grilles, especially on listed buildings, in conservation areas, on Buildings of Townscape Merit (BTMs), or in any environmentally sensitive location.

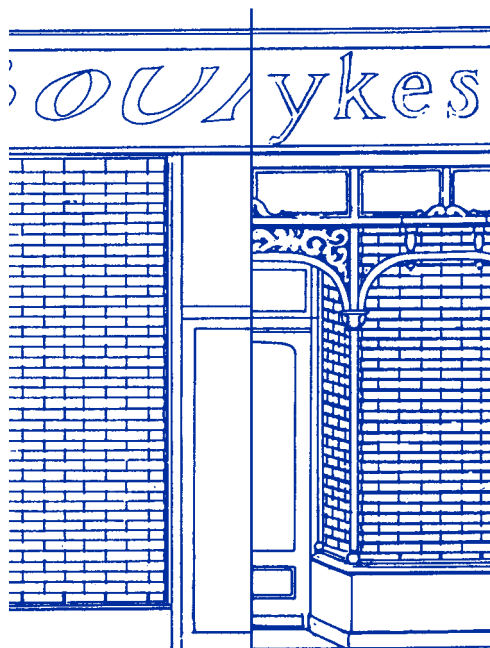

Modern shopfront

Traditional shopfront

However, in exceptional circumstances the installation of external brick bond pattern grilles will be considered on shopfronts if painted to match the shopfront and if the housing is hidden completely behind the fascia, and the guiding rails do not obscure any architectural features. Brick-bond grilles produce an effect unsympathetic to any sensitive environment, although to a lesser degree than solid or perforated shutters.

The security advantage of lattice brick-bond grilles over solid is that they allow greater visibility into shops, doing away with most of the problems associated with solid shutters listed above; they are also less prone to graffiti. While it is possible for a determined burglar to break the glass there is less likelihood of a vandal's missile having enough force to cause any damage to glazing. As with solid shutters, these do not offer the perfect solution in that an organised attack could pull the shutter off using ropes. However there is greater opportunity for passive surveillance from passers-by. Also goods on display are still visible which leads to a more user-friendly environment.

Side-hung scissor action grilles

In exceptional circumstances, painted side-hung scissor action grilles across doorways will be considered where it is not possible to hide the housing for an external brick-bond grille, providing that the housing for the scissor grille does not itself hide any architectural joinery.

Similar restrictions apply as to the brick-bond grille. This option can be a useful one where an external brick-bond grille would be the first choice but is not practically possible. It is not always necessary to extend the grille all the way across the shopfront and can be especially appropriate for blocking off recessed doorways.

Demountable solid timber shutters

In exceptional circumstances properly detailed, demountable solid painted timber shutters will be considered for some historic shopfronts.

While it is normally desirable to avoid any form of solid shutters in the interests of natural surveillance and a friendly environment, demountable solid timber shutters are a traditional solution if a severe problem exists and can be suitable to an historic environment. Their advantage over roller shutters is that they only cover the window area and not the entire shopfront, thus maintaining the integrity of both shop and street. They can also be considered in locations other than conservation areas and listed buildings. Suitably detailed demountable external snall meh grilles may be considered as an alternative, providing a view into the building.

Internal grilles

The Council considers that the internal grille is the only acceptable form of security in conservation areas, BTMs and listed buildings, other than in circumstances detailed elsewhere in this guidance.

The advantage of internal grilles in such a high quality environment as the Borough of Richmond upon Thames is the minimal impact they have on the external appearance of the shop front. Used with laminated glass they can provide an adequate level of protection for normal insurance purposes.

The disadvantage is that they do not provide the same level of protection for glazing as external shutters. However, one of the positive spin-offs of an attractive environment is that there are more people around and natural surveillance increases.

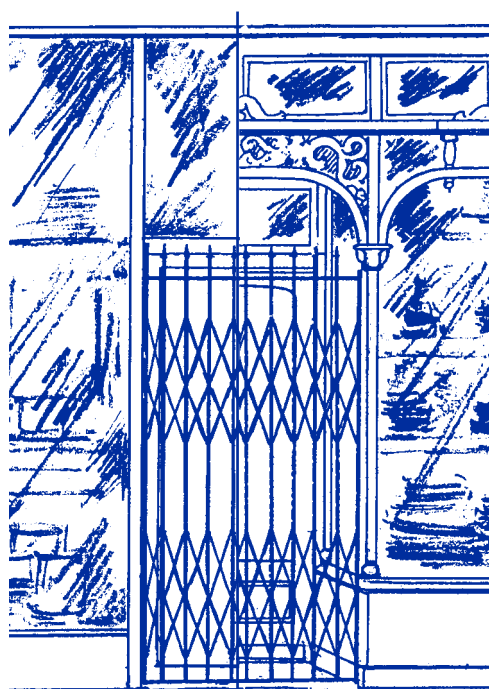

Modern shopfront

Traditional shopfront

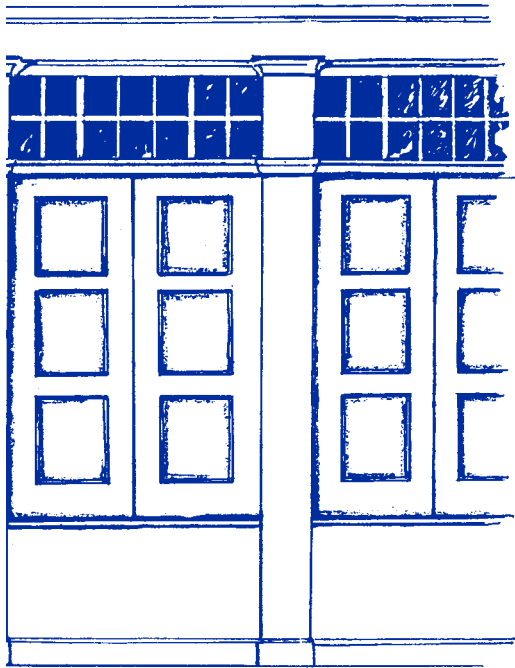

Solid timber shutters

New shopfronts

The Council will expect applicants for new shopfronts to demonstrate that the shopfront can sympathetically accommodate a suitable internal shutter housing and grille at a later date if necessary

The best way of dealing with shopfront security is to 'design it in' at the concept stage. This avoids many of the problems outlined elsewhere in this supplementary planning guidance.

Other useful security measures

Appropriate shutters are only one line of defence against unwanted vandalism and/or burglary.

What follows is a summary of other measures which retailers can take to secure their frontages. It should be stressed that these measures can be used as well as, and not instead of shutters. Where planning permission may be required this is made clear.

Under Building Regulations, all new shop fronts should be constructed using safety glass; this can be toughened or laminated. Toughened glass is five times stronger than ordinary glass and, when broken, disintegrates into blunt rather than sharp fragments. Its disadvantages are that if broken the whole window then goes and there can be a wait of some weeks before a new piece of toughened glass can be supplied. There are also limits to the size that can be produced, so it is more often used for shop doors than for windows.

Laminated glass has the advantage of staying in place when broken, which means that trade can continue until the window is repaired; it is also more readily available than toughened glass and can be cut to any size. For security purposes, thicknesses of 8.8mm and 10.8mm are recommended. If considering installing laminated glass, it is important to strengthen the joinery; otherwise this becomes the 'weak link' in the defence. This can be done from inside the shopfront and should not result in a change in the external appearance. If in doubt, or if the building is listed, check on the need for consent.

Stall risers

Fortunately, there have been few cases of ram raiding in the Borough.

However, there are precautions that can be taken other than cluttering the highway with bollards to prevent vehicles crashing through a shop front. The most effective of these utilises a traditional feature of shop front design, the stall riser. In some cases, an existing or new stall riser can be reinforced internally by brick or concrete block, or by other means.

However, in the case of shopfronts within listed buildings, particular care will be needed to avoid undue disturbance or damage to existing joinery and carpentry work of historic or architectural interest.

Insurers

It is suggested that insurers are consulted on any proposal before design work is commenced as they will be able to advise on security precautions that meet their policy requirements.

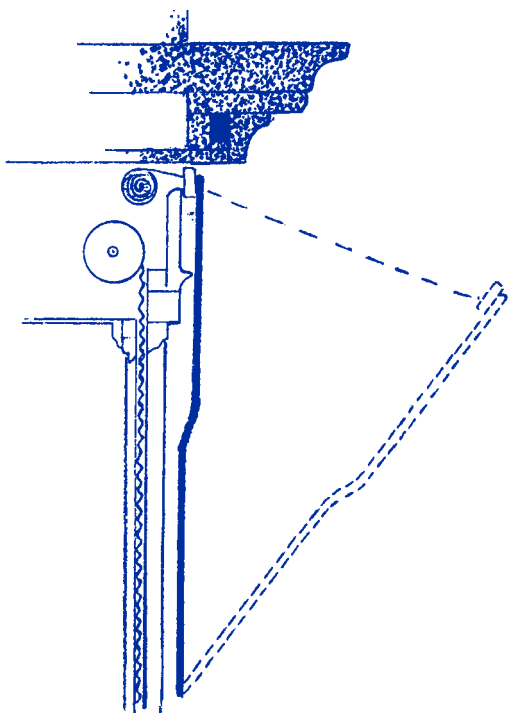

Section through fascia showing shutter and blind

FURTHER INFORMATION

Detailed information is contained in the following leaflets, available from the Development and Street Scene Department.

Design Guidelines

1. Shopfronts and Shop Signs
2. Car Parking in Front Gardens
- 3 & 4. External Alterations to Houses and House Extensions (Combined leaflet).
5. Trees: Planting, Care & Landscape Design
6. Small Housing Sites
7. Siting of Satellite Dishes
8. Wildlife in Front Gardens
9. Nature Conservation & Development
10. Security by Design
11. Shopfront Security

Planning Information Leaflets

1. Conservation Areas
2. Listed Buildings (important information for new owners)
3. Historic Buildings
4. Historic Buildings, Maintenance and Repair
5. Trees: Legislation & Procedure
6. Buildings of Townscape Merit

Contact numbers at the London Borough of Richmond upon Thames

Development control

E-mail: envprotection@richmond.gov.uk

Planning Support Centre for Development Control Inquires

Tel: 020 8891 7300

Environmental Health

Tel: 020 8891 7892

Building Control

Tel: 020 8891 7356/7357

Urban Design

Tel: 020 8891 7941/7335

If you need this leaflet in Braille,
large print, audio tape, or another language,
please contact us
on 020 88917322 or
minicom 020 88316001

Civic Centre 44 York Street
Twickenham TW1 3BZ
website: www.richmond.gov.uk

اگر در فهمیدن این نشریه مشکلی دارید لطفاً به میز پذیرش
در آدرس قید شده در زیر مراجعه نمایید تا ترتیب ترجمه
تلفنی برایتان فراهم آورده شود:

Farsi

إذا كانت لديك صعوبة في فهم هذا المنشور، فنرجو زيارة الإستقبال في
العنوان المعطى أدناه حيث بإمكاننا أن نرتب لخدمة ترجمة شفوية
هاتفية.

Arabic

ਜੇਕਰ ਤੁਹਾਨੂੰ ਇਸ ਪਰਚੇ ਨੂੰ ਸਮਝਣ ਵਿਚ ਮੁਸ਼ਕਲ ਪੇਸ਼ ਆਉਂਦੀ ਹੈ ਤਾਂ ਹੇਠਾਂ
ਦਿੱਤੇ ਗਏ ਪਤੇ ਉੱਪਰ ਰਿਸੈਪਸਨ 'ਤੇ ਆਓ ਜਿੱਥੇ ਅਸੀਂ ਟੈਲੀਫੋਨ ਤੇ ਗੱਲਬਾਤ
ਕਰਨ ਲਈ ਇੰਟਰਪ੍ਰਿਟਰ ਦਾ ਪ੍ਰਬੰਧ ਕਰ ਸਕਦੇ ਹਾਂ।

Punjabi

Reformatted with minor updates July 2005
(First published August 1997)

